

MONTÁŽNÍ VLOŽKA

PN 10 | PN 16 | PN 25

Konstrukční charakteristiky

- přírubová tvarovka umožňující podélnou kompenzaci potrubí
- jednoduchá montáž a demontáž
- díky závitovým tyčím nejsou potřebné další upevňovací šrouby (pouze u provedení s průběžnými šrouby)
- rozsah délkové nastavitelnosti: stavební délka L (viz tabulka) +/-25 mm
- rozměry a vrtání přírub dle EN 1092-2 | PN 10 | PN 16 | PN 25 (PN 40 na dotaz)
- k dodání také v provedení bez průběžných šroubů

Materiál

- 1 **příruba** z tvárné litiny s epoxidovou povrchovou úpravou
- 2 **upevňovací příruba** z oceli s epoxidovou povrchovou úpravou
- 3 **příruba** z tvárné litiny s epoxidovou povrchovou úpravou
- 4 **těsnění** z elastomeru
- 5 **závitová tyč** z pozinkované oceli
- 6 **matice** z pozinkované oceli

Montážní vložka č. 9810



obj.č.	PN	jmenovitá světlost / DN																								
		50	65	80	100	125	150	200	250	300	350	400	450	500	600	700	800	900	1000	1100	1200	1300	1400	1500	1600*	
9810	10																									
	16																									
	25																									

* větší DN a PN 40 na dotaz

Tlaková třída PN 10

DN	PN	L	L1	ØD	ØK	C	šrouby počet	Ø d2	hmotnost
50	10	180	280	165	125	19,0	4	19	11
65		180	280	185	145	19,0	4	19	13
80		200	330	200	160	19,0	8	19	17
100		200	330	220	180	19,0	8	19	20
125		200	330	250	210	19,0	8	19	24
150		200	330	285	240	19,0	8	23	30
200		200	330	340	295	20,0	8	23	42
250		220	360	405	350	22,0	12	23	62
300		220	360	460	400	24,5	12	23	67
350		230	360	505	460	24,5	16	23	85
400		230	370	565	515	24,5	16	28	105
450		250	390	615	565	25,5	20	28	131
500		260	390	670	620	26,5	20	28	155
600		260	410	780	725	30,0	20	31	225
700		260	410	895	840	32,5	24	31	300
800		290	460	1015	950	35,0	24	34	361
900		290	460	1115	1050	37,5	28	34	400
1000	290	500	1230	1160	40,0	28	37	516	
1100	300	480	1355	1270	53,5	32	37	830	
1200	320	520	1455	1380	45,0	32	41	895	
1300	370	630	1585	1490	59,0	32	42	1172	
1400	360	560	1675	1590	46,0	36	44	1194	
1500	380	590	1785	1700	47,0	36	44	1560	
1600	390	600	1915	1820	49,0	40	50	1436	

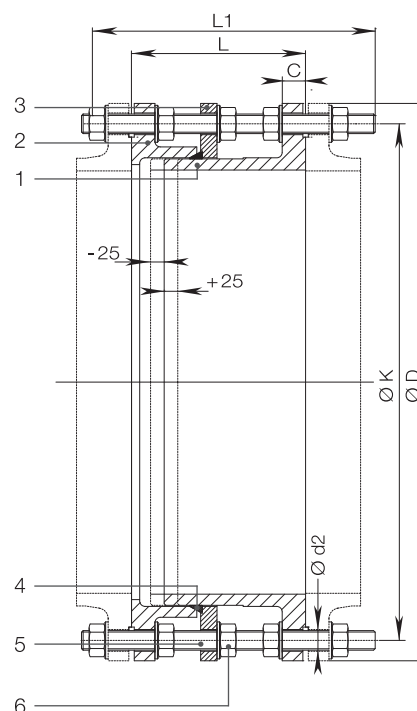

HAWLE ARMATURY, spol. s r.o. 252 42 Jesenice u Prahy - Česká republika - Říčanská 375
Tel.: +420 241 003 111 - Fax: +420 241 003 333 - e-mail: mail@hawle.cz - www.hawle.cz

D 6/1

MONTÁŽNÍ VLOŽKA

PN 10 | PN 16 | PN 25

č. 9810

Tlaková třída PN 16

DN	PN	L	L1	ØD	ØK	C	šrouby počet	Ød2	hmotnost
50	16	180	280	165	125	19,0	4	19	11
65		180	280	185	145	19,0	4	19	13
80		200	330	200	160	19,0	8	19	17
100		200	330	220	180	19,0	8	19	20
125		200	330	250	210	19,0	8	19	24
150		200	330	285	240	19,0	8	23	30
200		200	330	340	295	20,0	12	23	45
250		230	370	405	355	22,0	12	28	66
300		250	410	460	410	24,5	12	28	84
350		260	410	520	470	26,5	16	28	107
400		270	430	580	525	28,0	16	31	142
450		270	430	640	585	30,0	20	31	177
500		280	440	715	650	31,5	20	34	200
600		300	500	840	770	36,0	20	37	305
700		300	500	910	840	39,5	24	37	321
800		320	520	1025	950	43,0	24	41	469
900	320	520	1125	1050	46,5	28	41	535	
1000	340	560	1255	1170	50,0	28	44	698	
1100	340	560	1355	1270	53,5	32	44	830	
1200	360	600	1485	1390	57,0	32	50	1070	
1300	370	630	1585	1490	59,0	32	50	1172	
1400	380	630	1685	1590	60,0	36	50	1270	
1500	380	610	1820	1710	62,5	36	57	1560	
1600	400	700	1930	1820	65,0	40	57	1705	

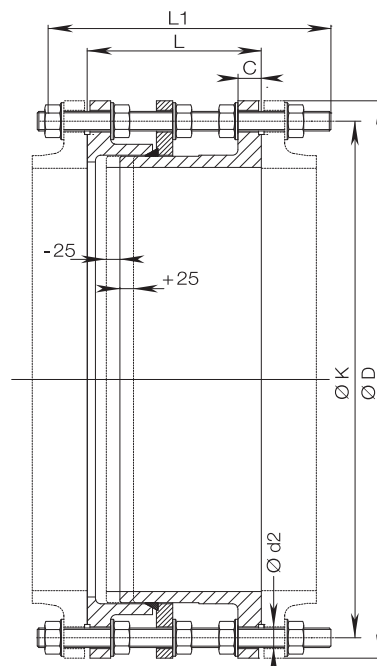

č. 9810

Tlaková třída PN 25

DN	PN	L	L1	ØD	ØK	C	šrouby počet	Ød2	hmotnost
100	25	220	340	235	190	19,0	8	23	32
125		220	370	270	220	19,0	8	28	43
150		230	370	300	250	20,0	8	28	52
200		230	370	360	310	22,0	12	28	76
250		250	410	425	370	24,5	12	31	108
300		250	410	485	430	27,5	16	31	129
350		270	480	555	490	30,0	16	34	196
400		280	500	620	550	32,0	16	37	212
450		280	480	670	600	34,5	20	37	281
500		300	500	730	660	36,5	20	37	290
600		320	520	845	770	42,0	20	41	389
700		340	530	960	875	46,5	24	44	505
800	360	600	1085	990	51,0	24	50	690	
900	380	600	1185	1090	55,5	28	50	920	
1000	400	650	1320	1210	60,0	28	57	1257	
1200	450	720	1530	1420	69,0	32	57	1870	

D 6/2

HAWLE ARMATURY, spol. s r.o. 252 42 Jesenice u Prahy - Česká republika - Říčanská 375
Tel.: +420 241 003 111 - Fax: +420 241 003 333 - e-mail: mail@hawle.cz - www.hawle.cz